

*“Making The Switch”*

Michael Moran

Product & Support Technologist

## Signal Switching in Modern Test Systems

Test system designers are vitally concerned with connecting signals between their instrumentation and the products under test. These connections have to be reliable and inexpensive, to occupy minimal space in the system chassis, and to satisfy the need for routing and re-routing scarce resources as quickly as possible. To meet this need Digalog created the DigESwitch product line, a series of 2U rack-mount switching solutions available in single-ended matrix, and differential mux configurations.

Signal generation and measurement resources can be expensive, and how they’re utilized can significantly impact overall test system cost. A properly specified switching subsystem can help to hold costs in line. By dynamically creating and removing “on-the-fly” the complex interconnections required between system resources and the DUT (Device Under Test), the switching subsystem allows one set of resources to reach every pin of the DUT and avoid the need for multiple identical resources.

A number of issues bear directly on the specification of a switching subsystem. These may include rack space and switch density, control, integration with other test system components, communication, speed, programming, fixture requirements, and of course cost. In this white paper we’ll examine these factors and show how DigESwitch addresses each. First, we’ll define what we mean by a “switch.”

## Switch Architecture

At its most fundamental, a switch is a binary device that performs a simple function. In one state, it creates an electrical connection between two points and in the other, it breaks the connection. Switches come in three basic configurations:



Form A



Form B

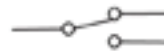

Form C

The Form A switch, also known as Single Pole Single Throw or SPST, holds the connection open in its “normal” or inactivated state and creates the connection when activated. The Form B switch is just the opposite. Form C, also known as Single Pole Double Throw or SPDT, connects its common terminal to one side in the normal state and to the other side when activated.

Test systems often employ more complex switching architectures like multiplexer and matrix. Each takes advantage of the fact that of all the available switching paths in a test system, in normal operation only a small proportion need to be active at any given moment.

A multiplexer or “mux” allows any one of two or more inputs to be routed to the output. As shown below, the usual designation for a multiplexer is n:1, where n is the number of inputs. When used in the reverse direction so that one input can be routed to any of multiple outputs, it is known as a demultiplexer. While a basic multiplexer allows only one input at a time to be connected to the output, more versatile designs allow multiple inputs at a time.

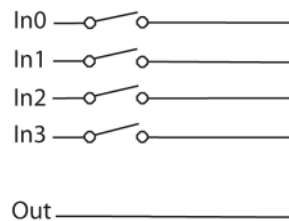

4:1 Multiplexer

The matrix architecture expands upon the multiplexer by adding additional output paths (generally referred to as “buses”) and allowing any number of inputs or “channels” to be connected to a given bus at a time. While a matrix will usually bear a higher price tag than the simpler architectures, its increased versatility will often make it the more cost-effective solution overall. Switch matrices are designated as “N x M” where N refers to the number of channels and M to the number of buses.

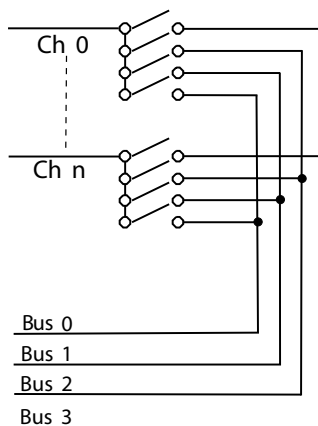

(n + 1) x 4 Matrix

Now that we’ve seen how the common switch architectures work, let’s delve a little deeper into some of the important issues encountered in specifying a test system’s switching subsystem.

### Rack Space and Switch Density

Space is expensive. Whether in the lab or in production, a multiple-rack test system demands extra floor space, something that often is at a premium. While a single tall rack offers a smaller footprint, it will be heavy, unwieldy to install or move, and can complicate maintenance and configuration efforts. Nevertheless, test systems often need to be in a single 19 inch rack. DigESwitch helps the system designer minimize space demands and keep the overall size of the rack manageable.

DigESwitch requires only 2U (approximately 3½ inches) of vertical space and 18 inches of depth in a standard 19 inch rack, making it one of the slimmest, most space-efficient system components in today’s test and measurement marketplace. In the matrix configuration, its ten models accommodate four or eight isolated buses with up to 460 channels in the same 2U form factor. The five differential models offer up to 50 independent 2:1 differential mux channels, while the five Form-A models feature up to 160 channels. At full-capacity configuration, 2300 channels of single-ended matrix switching, 600 Form-A channels, or 250 channels of 2:1 differential muxing can be assembled into less than 18 inches of vertical rack space.

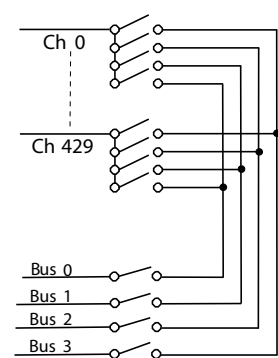

DigESwitch 4-Bus Matrix

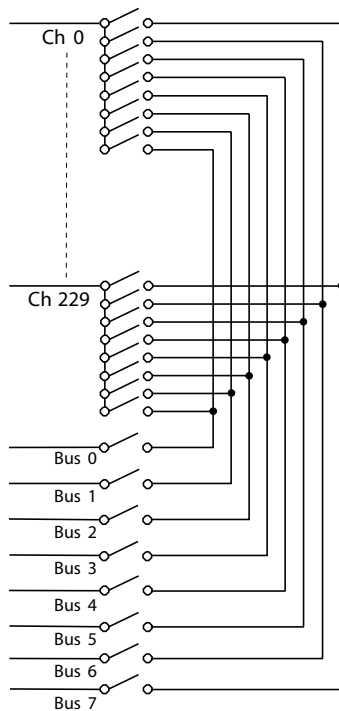

DigESwitch 8-Bus Matrix

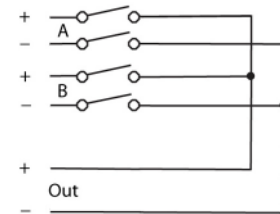

DigESwitch Differential Mux-(one channel shown)

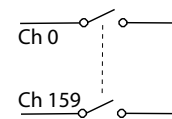

DigESwitch Form A

## Integration

Realizing a mixed-technology, mixed-vendor test system calls for careful analysis and planning in the design phase. While power requirements are largely standardized around the commercial AC grid, the physical, electrical and software aspects of ensuring that each system component “works and plays well with others” can pose significant challenges.

As a stand-alone system component, DigESwitch accepts the standard range of commercial AC power: 90 to 264VAC at 47-63Hz. Control and communication interfacing consists of a single CAT-5 Ethernet cable on the rear panel, while I/O connections are by means of front-mounted off-the-shelf high-density connectors. DigESwitch can integrate easily into systems that employ any mixture of standalone and modular instrumentation bus technologies because it imposes no unique requirements on them.

On the software side, DigESwitch offers a selection of programming and control options with support for the industry-standard IVI driver specification and for National Instruments® Switch Executive®, along with the simplicity of a Direct I/O Driver callable from C and C++. This allows wide latitude in the design of new systems as well as facilitating the integration of DigESwitch into existing ones.

## Control, Communication and Speed

The hardware instrumentation bus chosen for a test system is the most important determiner of raw communication speed to and from the instruments. Bus technologies may be broadly divided into “standalone” and “modular” categories, and most test systems will employ both. The most common modular buses include the ubiquitous PCI (Peripheral Component Interconnect) bus found in virtually every personal computer and its recently-introduced successor PCI Express, PXI (PCI eXtensions for Instrumentation), and VXI (VME eXtensions for Instrumentation). Each is a “plug-in” architecture where the actual instruments take the form of cards or modules which are mated with standardized sockets inside a computer or other chassis, from which the instruments draw their communication connections to the system computer and their power connections.

Among stand-alone buses, GPIB (General Purpose Interface Bus) is probably the best known and most widely used. Introduced by Hewlett-Packard (now Agilent) in the 1960s and standardized as IEEE-488 the following decade, GPIB offers a relatively slow data transfer rate of up to 8MB/s. The bus can accommodate one controller (usually in the form of a card which plugs into one of the modular buses detailed above) and up to 14 instruments, with a maximum cable length of 20 meters unless extenders are employed. GPIB cables and connectors, while relatively expensive, are rugged and industrially-graded which makes them suitable for nearly any environment

The venerable RS-232 serial bus has been widely implemented in many types of instrumentation and industrial applications over the years. Although largely obsolete in terms of performance, it is still found on many PCs and used to control devices like printers and modems. For control of instruments in modern test systems, it suffers from severe limitations including very slow data rates and the inability to connect more than one device at a time. Few new instruments incorporate an RS-232 port, and this bus would not be a good choice for a new system.

Universal Serial Bus (USB) lives up to its name, having replaced, on modern PCs, most of the “legacy” ports such as serial, parallel, and PS/2. USB was conceived primarily for this application and so is designed to be as user-friendly as possible. It is a plug-and-play technology which automatically detects a new device and configures the appropriate drivers so that all a computer user need do is plug the device into an available USB port and the computer will do the rest. Depending on the particular implementation, USB offers communication speeds from 1.5Mbps for the older 1.1 specification all the way to 480Mbps for the more recent USB 2.0. Despite its wide availability and speed, it suffers from serious drawbacks for instrumentation control. USB cables are not industrial grade, which can result in data loss and corruption in electrically noisy environments. In addition, the connectors do not have a latching mechanism, so they can easily be pulled loose from the PC or instrument.

Ethernet has been for many years the de-facto standard of computer networking. A relative newcomer to instrumentation control, Ethernet is in fact the base technology behind the LXI (Lan eXtensions for Instrumentation) standard, which was introduced in 2005 and is administered by the LXI Consortium of which Digalog is a member. LXI augments Ethernet’s basic features and abilities with instrumentation-specific extensions like trigger functionality and the IEEE-1588 precision time synchronization protocol.

An estimated 100 million computers in the world use Ethernet for networking, a market whose sheer size has driven the price of an Ethernet interface, whether embedded or in the form of a modular card, to the level of a commodity. This alone makes Ethernet an attractive option for cost-sensitive test applications. A wide variety of interconnection, sharing and extension devices exist for Ethernet. All benefit from the same volume-based pricing structure, which allows the inexpensive configuration of multiple-unit Ethernet-based instrument networks.

While cost is always a consideration, it is not the most important one. Current Ethernet technology supports transfer rates as high as 1Gbps, and the world's relentless hunger for data communications bandwidth will soon bring 10Gbps to the market. These speeds substantially exceed those available from other standalone bus technologies. Because Ethernet's introduction to the instrumentation world is so recent, Ethernet-based instruments also benefit from the incorporation of newer industry-standard programming technologies and software re-use principles, which helps reduce the time required to create and maintain test programs.

DigESwitch's 10/100BaseT Ethernet interface makes it compatible with nearly every Ethernet-equipped device in use, bringing the familiar, time-proven versatility and reliability of computer networking technology to the test instrumentation rack.

In summary, while no one bus technology may be considered as the universally optimal solution, Ethernet and the associated TCP/IP protocol suite offer compelling advantages to test system designers. Proven, inexpensive and ubiquitous, Ethernet and its instrumentation-specific extensions embodied in the LXI standard are poised to drive test system design to new levels of function and productivity.

## Programming

The complexity of products to be tested results in equal complexity of test programs. The test and measurement industry has met this challenge by adopting a number of standardized programming environments and languages. Those based on the C programming language, such as LabWindows/CVI®, C++ and C#, find wide favor in the engineering community.

The drive for standardization has also given rise to the concept of Interchangeable Virtual Instrumentation or IVI, whose purpose is to ease the task of system configuration and programming by implementing a comprehensive set of vendor-neutral software functions. Instruments of the same class compliant to the IVI standard ideally can be directly substituted for one another regardless of manufacturer, with no accompanying changes to the controlling software.

In addition, the complex task of efficiently configuring large switching arrays has spurred the development of graphical switch programming environments such as National Instruments® Switch Executive.

DigESwitch implements all of these with a Direct I/O driver whose functions are callable from the C family of languages, an IVI driver fully compliant with the IVI Switch Class Specification 3.0, and support for Switch Executive®

## Fixture Requirements

Fixturing, the interface between test system and product UUT (Unit Under Test), has a considerable impact on the total cost of a test solution, not just for the initial purchase price but for ongoing maintenance and for the inevitable modifications made necessary by product changes. Any feature of a system component which reduces fixture complexity will produce cost savings not just immediately, but every time an additional fixture needs to be constructed for a new or significantly changed product.

In the matrix models, DigESwitch's hardware architecture includes internal isolation relays between its buses and the connector pins which bring them to the outside world. This allows the buses to be completely disconnected, an ability analogous to the high-impedance or "Tri-State" feature of digital logic ICs which enables their outputs to be connected directly together without using additional isolation components.

This important feature allows multiple switch banks to be wired directly together while eliminating the extra wiring and components such as relays and power supplies which would be needed to implement this functionality within the fixture itself.

## Cost

As a standalone component whose only system interface requirement is an Ethernet cable, DigESwitch can bring significant cost savings to test system design. For example, numerous manufacturers offer PXI or VXI switching modules but these, obviously, require a corresponding chassis. If the test system in question does not already have one, it would be an expensive proposition to add an entire PXI or VXI subsystem simply to implement the needed switching functions.

Even in systems already based on these modular buses, the per-switch cost of DigESwitch will often be lower and a DigESwitch solution does not consume slots in the chassis which might be better dedicated to other instrumentation.

DigESwitch is available in five Form-A, ten matrix and five differential configurations. Form-A configurations come with 32, 64, 96, 128, or 160 independent channels. Matrix models with eight buses feature channel capacities of 46, 92, 138, 184 and 230, while the four-bus models increase the channel count to 92, 184, 276, 368 or 430. Differential models offer 10, 20, 30, 40 or 50 independent 2:1 differential mux channels with A, B, AB and disconnect modes. This architecture lets you conserve budget by purchasing sufficient capacity to serve current needs, with room for expansion as system requirements grow.

## Summary

The components available for today's test systems offer capabilities that just a few years ago either did not exist or could not be economically justified for any application in which cost was more than a peripheral factor.

These capabilities come with the price of complexity, in both hardware and software requirements. An appropriately specified switching subsystem which integrates easily with other components is a proven way to help bring this complexity under control.

With its high-speed Ethernet communications interface, space-saving form factor, high switch density, variety of switch architectures, full support for multiple programming environments and ease of fixture interfacing, DigESwitch represents a versatile and cost-effective signal switching solution for test and instrumentation systems of any size.

### *About the author*

Michael Moran joined Digalog in 1995. His background includes broadcasting, commercial and public safety wireless communications, circuit design, computers, and technical documentation. He has extensive experience supporting and training Digalog's world-wide customer base on-site and remotely in the USA and overseas.

### *For more information, contact Digalog Systems at:*

3180 S. 166<sup>th</sup> Street  
New Berlin, WI 53131  
Phone: 262-797-8000  
Fax: 262-797-8003  
E-mail: [sales@digalogsys.com](mailto:sales@digalogsys.com)  
Website: <http://www.digalogsystems.com>

